

J.L. WINGERT CO.

P.O. Box 6207 • Garden Grove, CA 92846-6207 / 11800 Monarch Street • Garden Grove, CA 92841-2113
 Phone (714) 379-5519 • Fax (714) 379-5549 ■ Email: customerservice@jllwingert.com
 Northern California Region • Phone (510) 487-5310 ■ Southwest Region • Phone (602) 470-1015
 www.jllwingert.com

MANUFACTURING: Mixers, Bypass Feeders, Filter Feeders, Bromine Feeders, Sample Coolers, Sludge Traps, Separators, Separator Systems, Tank Stands,
 Tank Package Systems, Glycol Feed Systems, Coupon Racks, Control Stations, NEMA Enclosures, Custom Packaged Systems and Specialty Welding

Specification Sheet #032010 Rev. "C" (12/99)

DOME BOTTOM HIGH CAPACITY FILTER FEEDERS

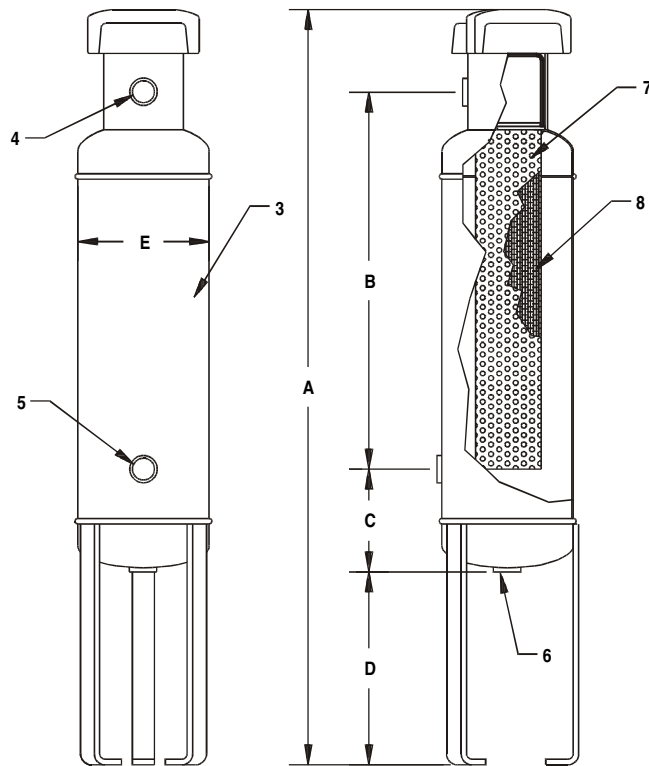
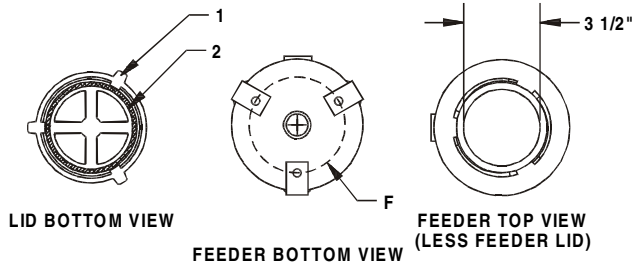

PARTS, MATERIALS AND SPECIFICATIONS:

KEY	PART	SPECIFICATIONS
1	3071	CLOSURE: 3 1/2" cast iron, 1/4 turn closure (O-ring included)
2	3072	O-RING: Buna-N O-ring 200° F
3		BODY: Carbon steel
4		INLET: 3/4" FNPT
5		OUTLET: 3/4" FNPT
6		DRAIN: 3/4" FNPT
7	3160	BASKET: 304 stainless steel basket (2.5"D x 19"L)
8	3161	FILTER: 25 micron bag (2.5"D x 19"L / 93 in ²)
MAX. PRESSURE		200 PSI (13.6 BAR)
MAX. TEMPERATURE		200° F (93° C)

VOLUME (FILL CAPACITY)

MODEL	GALLONS	LITERS
FHC-DB-2HD	2.48	9.39
FHC-DB-5HD	6.39	24.19
FHC-DB-12HD	13.37	50.61

DIMENSIONS, WEIGHT & CUBE:

KEY	FHC-DB-2HD	FHC-DB-5HD	FHC-DB-12HD
A	34 3/4"	34 7/8"	55 3/8"
B	17 1/4"	16 3/4"	37 1/4"
C	4 3/4"	6 1/2"	6 1/2"
D	8 3/4"	7 3/4"	7 3/4"
E	6"	10"	10"
F	4"	8"	8"
WEIGHT	30 lbs. (13.6 kgs.)	44 lbs. (20 kgs.)	69 lbs. (31.3 kgs.)
CUBE	6" X 6" X 35"	10" X 10" X 35"	10" X 10" X 56"

Note: All dimensions are +/- 1/8". All weights are approximate. All dimensions are subject to change without notice.