

# J.L. WINGERT CO.

P.O. Box 6207 • Garden Grove, CA 92846-6207 / 11800 Monarch Street • Garden Grove, CA 92841-2113  
 Phone (714) 379-5519 • Fax (714) 379-5549 ■ Email: customerservice@jllwingert.com  
 Northern California Region • Phone (510) 487-5310 ■ Southwest Region • Phone (602) 470-1015  
 www.jllwingert.com

MANUFACTURING: Mixers, Bypass Feeders, Filter Feeders, Bromine Feeders, Sample Coolers, Sludge Traps, Separators, Separator Systems, Tank Stands,  
 Tank Package Systems, Glycol Feed Systems, Coupon Racks, Control Stations, NEMA Enclosures, Custom Packaged Systems and Specialty Welding

Specification Sheet #032007 Rev. "E" (3/01)

## FLAT BOTTOM FILTER FEEDERS

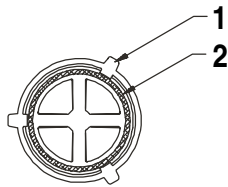

LID BOTTOM VIEW

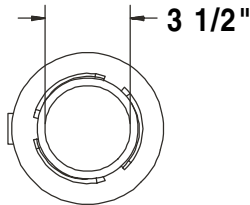

FEEDER TOP VIEW  
(LESS FEEDER LID)

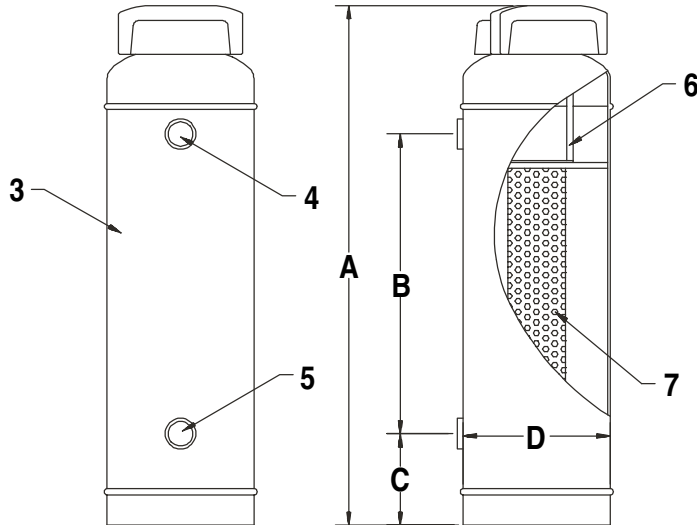

### PARTS, MATERIALS AND SPECIFICATIONS:

KEY	PART	SPECIFICATIONS
1	3071	CLOSURE: 3 1/2" cast iron, 1/4 turn closure. (O-ring included)
2	3072	O-RING: Buna-N O-ring 200° F
3		BODY: Carbon steel
4		ENTRY: 3/4" FNPT
5		EXIT: 3/4" FNPT
6	3128	BASKET: 304 stainless steel basket (2"D x 9"L)
	3129	BASKET: 304 stainless steel basket (2"D x 24"L)
7	3131	FILTER: 25 micron bag (2"D x 9"L) 28 c.i. capacity
	3132	FILTER: 25 micron bag (2"D x 24"L) 75c.i. capacity
MAX. PRESSURE		200 PSI (13.6 BAR)
MAX. TEMPERATURE		200° F (93° C)

### VOLUME (FILL CAPACITY)

MODEL	GALLONS	LITERS
F-2HD	2.16	8.17
F-5HD	5.79	21.92
F-12HD	12.76	48.30

### DIMENSIONS, WEIGHT AND CUBE:

KEY	F-2HD	F-5HD	F-12HD
A	21 1/8"	21 5/8"	42"
B	12"	11"	31"
C	3 3/4"	4"	4 1/4"
D	6"	10"	10"
WEIGHT	21 lbs. (9.5 kgs.) approx.	38 lbs. (17.3 kgs.) approx.	64 lbs. (29.1 kgs.) approx.
CUBE	6" X 6" X 22"	10" X 10" X 22"	10" X 10" X 44"

Note: All dimensions are +/- 1/8". All weights are approximate. All dimensions are subject to change without notice.