

# J.L. WINGERT CO.

P.O. Box 6207 • Garden Grove, CA 92846-6207 / 11800 Monarch Street • Garden Grove, CA 92841-2113  
 Phone (714) 379-5519 • Fax (714) 379-5549 ■ Email: customerservice@jllwingert.com  
 Northern California Region • Phone (510) 487-5310 ■ Southwest Region • Phone (602) 470-1015  
 www.jllwingert.com

MANUFACTURING: Mixers, Bypass Feeders, Filter Feeders, Bromine Feeders, Sample Coolers, Sludge Traps, Separators, Separator Systems, Tank Stands,  
 Tank Package Systems, Glycol Feed Systems, Coupon Racks, Control Stations, NEMA Enclosures, Custom Packaged Systems and Specialty Welding

Specification Sheet #032003 Rev. "F" (12/99)

## HIGH PRESSURE BYPASS FEEDERS

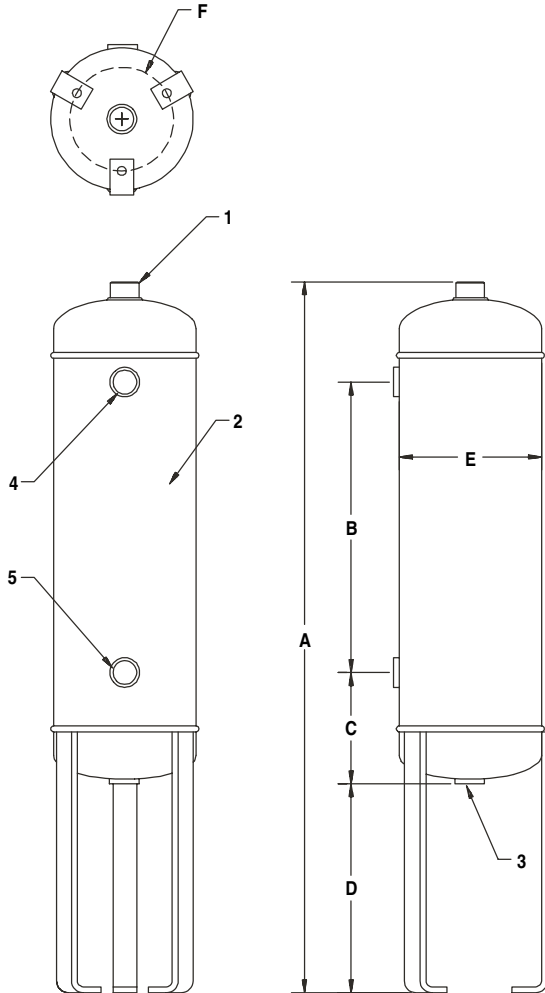

### MATERIALS AND SPECIFICATIONS:

| KEY              | SPECIFICATIONS     |
|------------------|--------------------|
| 1                | FILL: 1" FNPT      |
| 2                | BODY: Carbon steel |
| 3                | DRAIN: 3/4" FNPT   |
| 4                | OUTLET: 3/4" FNPT  |
| 5                | INLET: 3/4" FNPT   |
| MAX. PRESSURE    | 300 PSI (20.7 BAR) |
| MAX. TEMPERATURE | 200° F (93° C)     |

### VOLUME (FILL CAPACITY)

| MODEL     | GALLONS | LITERS |
|-----------|---------|--------|
| HP-1      | 1.19    | 4.52   |
| HP-2-LEG  | 2.39    | 9.04   |
| HP-5-LEG  | 6.30    | 23.85  |
| HP-12-LEG | 13.28   | 50.27  |

### DIMENSIONS, WEIGHT & CUBE:

| KEY    | HP-1              | HP-2-LEG           | HP-5-LEG            | HP-12-LEG           |
|--------|-------------------|--------------------|---------------------|---------------------|
| A      | 12 3/16"          | 30 3/8"            | 30 3/4"             | 51 1/4"             |
| B      | 3 1/2"            | 12 1/2"            | 10 3/4"             | 31"                 |
| C      | 4"                | 4 3/4"             | 6 1/2"              | 6 1/2"              |
| D      | N/A               | 8 3/4"             | 7 3/4"              | 7 3/4"              |
| E      | 6"                | 6"                 | 10"                 | 10"                 |
| F      | N/A               | 4"                 | 8"                  | 8"                  |
| WEIGHT | 8 lbs. (3.6 kgs.) | 16 lbs. (7.3 kgs.) | 31 lbs. (14.1 kgs.) | 56 lbs. (25.4 kgs.) |
| CUBE   | 6" X 6" X 12"     | 6" X 6" X 32"      | 10" X 10" X 32"     | 10" X 10" X 52"     |

Note: All dimensions are +/- 1/8". All weights are approximate. All dimensions are subject to change without notice.